



# Fantech

## Heat Recovery Ventilator

# VH704

**V** = Vertical discharge  
**H** = Heat recovery  
**704** = 70cfm, 4 port design

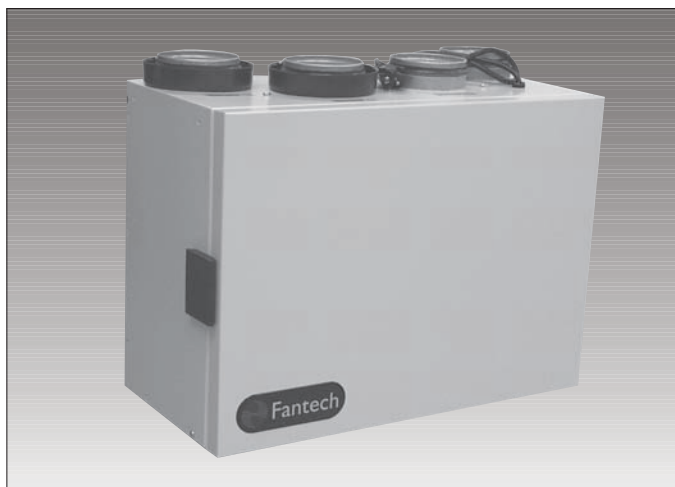

Compact top port design HRV with easy-mount wall bracket. Brings a continuous supply of fresh air into a home while exhausting an equal amount of contaminated air. HRVs use what is called a "sensible" heat recovery core. This special core transfers heat from the exhaust air stream to the incoming air stream. Fresh incoming air is tempered by the heat that is transferred from the outgoing air to save on energy costs. The VH704 is equipped with automatic defrost mechanisms so even if you live in the coldest climates you can use your HRV all year long.

### FEATURES

- Super Compact Size
- Top Port Design Fits in Tight Spaces
- Includes Easy-Mount Wall Bracket
- Aluminum Heat Recovery Core
- 4" (100mm) Duct Connections
- No Balancing Required
- Easy Access Service Door
- 3' (914mm) Plug-in Power Cord
- Automatic Exhaust Defrost Allows Units to Always Stay in Ventilation Mode
- Only 26 lbs (12 kg)
- Electrostatic Filters (washable)
- Easy Core Guide Channels For Removing Core
- Single Speed Ventilation

### ACCESSORIES

- FDT 7 – 7 Day Digital Programmable Timer
- COM 4P – 4" Weather Hoods (1 supply & 1 exhaust)
- FEL 4 – 4" 90° Elbow
- CG 4 – 4" Adjustable Grille

Distributed by:

### SPECIFICATIONS

**CASE** 24 gauge galvanized steel. Baked powder coated paint, antique white. Cabinet fully insulated with 1" (25 mm) aluminum foil-face high density polystyrene foam to prevent condensation and meet the requirements of the UL 94HF.

**MOTORS** Two (2) German-manufactured, factory-balanced ebm™ motors with backward curved blades. Motors come with permanently lubricated sealed ball bearings to guarantee long life and maintenance-free operation. Seven (7) year warranty. Steep fan curves requires no balancing of airflows.

**CORE** Aluminum heat recovery core configured for efficient cross-flow ventilation. Core is 8.5" x 8.5" (216 x 216 mm) with a 8" (205 mm) depth. Cores are manufactured by Fantech to withstand extreme temperature variations.

**FILTERS** Two (2) Washable Electrostatic Panel Type Air Filters, 8.5" (216mm) x 8" (203mm) x 0.125" (3mm).

**CONTROLS** Unit is designed to operate continuously on a single speed. See FDT 7 under accessories or contact Tech Support for possible intermittent, line-voltage options.

**DEFROST** The automatic defrost cycle consists of a fan shutdown. When the supply air stream temperature goes below 23°F (-5°C), the supply motor shuts down while the exhaust motor continues to ventilate. Ambient air is passed through the unit for a period of 3 or 5 minutes. (see chart below) The supply motor will then re-start and run at the preset speed. This fan shutdown defrost cycle continues until the supply air stream rises above 23°F (-5°C).

<i>Temperature range</i> °F (°C)	<i>Run/Defrost cycle</i> (minutes)
23 (-5) to 14 (-10)	40 / 3
14 (-10) to 5 (-15)	30 / 5
5 (-15) & lower	20 / 5

**SERVICEABILITY** Core, filters, motors and drain pan can be easily accessed through latched door. Core conveniently slides out on our new easy glide core guides. 10" (250mm) of clearance is recommended for removal of core.

**DUCT CONNECTION** 4" (100mm) steel duct connections with rubber gasket for easy sealing.

**DRAIN** 1/2" (13mm) OD (outside diameter) drain spout provided, entire bottom of unit covered by pan.

**WARRANTY** Limited lifetime on aluminum core, 7 year on motors, and 5 year on parts.

**Dimensions & Airflow** - All units feature three foot plug-in power cord with 3-prong plug.

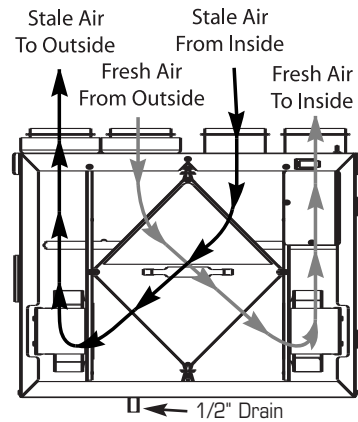
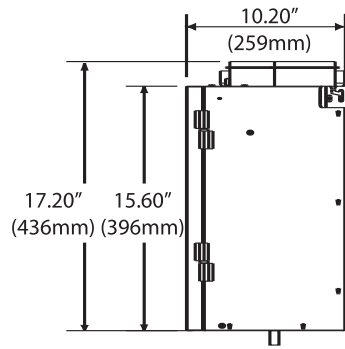
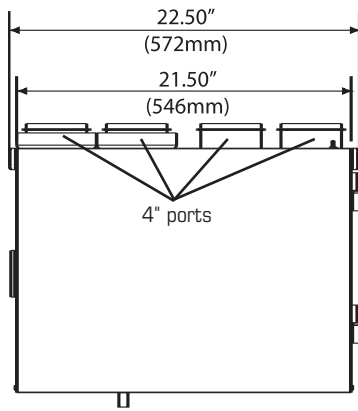

- Continuous ventilation mode of supply and exhaust airstreams
- 10" (254mm) of clearance is recommended for removal of core

**Ventilation Performance**

EXT. STATIC PRESSURE		NET SUPPLY AIR FLOW		GROSS AIR FLOW			
				SUPPLY		EXHAUST	
Pa	in wg	L/s	cfm	L/s	cfm	L/s	cfm
25	0.1	45	96	47	99	49	104
50	0.2	40	85	41	88	41	88
75	0.3	32	67	33	69	34	72
100	0.4	26	56	27	58	28	58
125	0.5	20	42	20	43	20	43

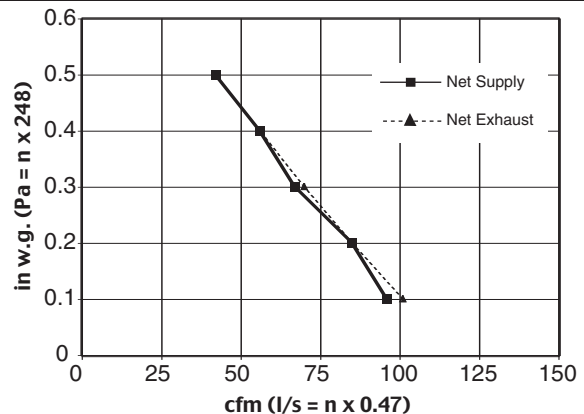

**Energy Performance**

	SUPPLY TEMPERATURE		NET AIRFLOW		POWER CONSUMED WATTS	SENSIBLE RECOVERY EFFICIENCY	APPARENT SENSIBLE EFFEC-TIVENESS	LATENT RECOVERY/MOISTURE TRANSFER
	°C	°F	L/s	cfm				
Heating	0	32	26	55	36	57	67	-
	0	32	32	68	40	55	63	-
	0	32	39	83	40	54	60	-
	-25	-13	34	72	35	53	66	-

**Specifications and Ratings**

- Model: VH704
- Total assembled weight: 26 lbs (12kg)
- Cabinet: 24 ga. steel w/powder coat finish
- Motors: ebm motors w/backward curved blades
- Filters: 2 washable electrostatic filters 8.5" (216mm) x 8" (205mm) x 0.125" (3mm)
- Insulated with 1" (25 mm) aluminum foil-face high density polystyrene foam to prevent condensation and meet the requirements of the UL 94HF.
- Core: Aluminum 8.5" (216mm) x 8.5" (216mm) x 8" (205mm)
- Supply & exhaust ducts: 4" (100mm)
- Mounting: Wall bracket included
- Electrical requirements:
 

Volts	Frequency	Amps	Watts
115V	60Hz	0.36A	40W

 3' plug-in power cord w/ 3-prong plug

**Contacts**

Submitted by: \_\_\_\_\_ Date: \_\_\_\_\_

Qty: \_\_\_\_\_ Model #: \_\_\_\_\_

Comments: \_\_\_\_\_

Project #: \_\_\_\_\_

Location: \_\_\_\_\_

Architect: \_\_\_\_\_

Engineer: \_\_\_\_\_

Contractor: \_\_\_\_\_



United States  
 1712 Northgate Blvd.,  
 Sarasota, FL. 34234  
 (T) 1.800.747.1762  
 (F) 1.800.487.9915  
 (T) 1.941.309.6000  
 (F) 1.941.309.6099  
 www.fantech.net  
 info@fantech.net

Canada  
 50 Kanalfakt Way,  
 Bouctouche, NB E4S 3M5  
 (T) 1.800.565.3548  
 (F) 1.877.747.8116  
 (T) 1.506.743.9500  
 (F) 1.506.743.9600  
 www.fantech.ca  
 info@fantech.ca



Article #: 403298  
 Rev Date: 072808