



Fantech

Whole House HEPA Filtration

Whole House HEPA Filtration System

Model DM3000P

- Uniquely Designed for Superior Performance
- Backed by a 7-Year Motor Warranty



Pre-filter

Carbon Filter

Certified HEPA Filter

**99.97%
Effective**
Down to 0.3 microns

**Featuring
Integrated Airflow
Sensor Switch**
Energizes the unit anytime
furnace / air handler operates.

FEATURES

- Certified HEPA Filter Media
- Duct Mount Design
- Built-in Airflow Sensor Switch
- Template Provided for Duct Cut-Out
- Easy Mount Seal Plate for Quick Installations
- Virtually Zero Filter By-Pass in Cabinet
- Fantech's Flobaffle Technology
- ebm® Motor with Backward Incline Impeller
Means Efficient Airflow Even as Filter Loads
- Effortless Swing-Open Access Door for Easy Service
- Powder Coated Cabinet
- 5' Power Cord with 3-Prong Plug-in

True HEPA Filtration for Your Entire Home!

- Collects 99.97% of airborne particles and allergens down to 0.3 microns including smoke and dust particles, animal dander, dust mites, bacteria and attached viruses
- Cleans the air in an average house once each hour
- Easily connects to existing ductwork of forced air furnace or air handler

So Easy to Install!

- Horizontal or vertical installation
- Can be installed independently, on your furnace, air handler, or combined with your ventilation system
- Duct template and easy-mount seal plate provided
- Built-in pressure switch turns on HEPA unit anytime furnace blower is energized
- No wiring required

Horizontal or Vertical Installation!

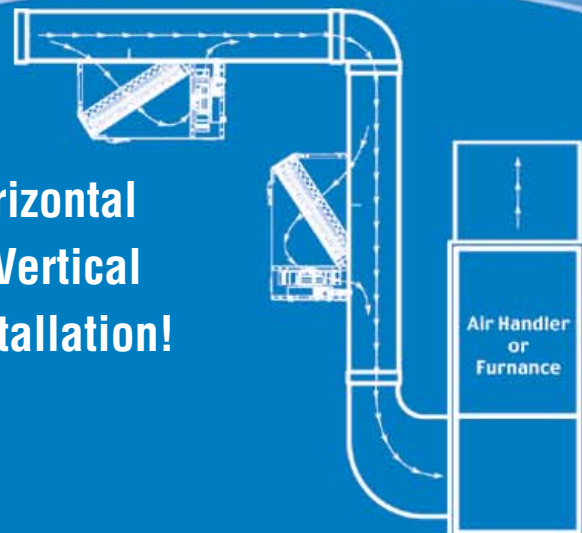

Dimensions & Airflow - All units feature five foot plug-in power cord with 3-prong plug.

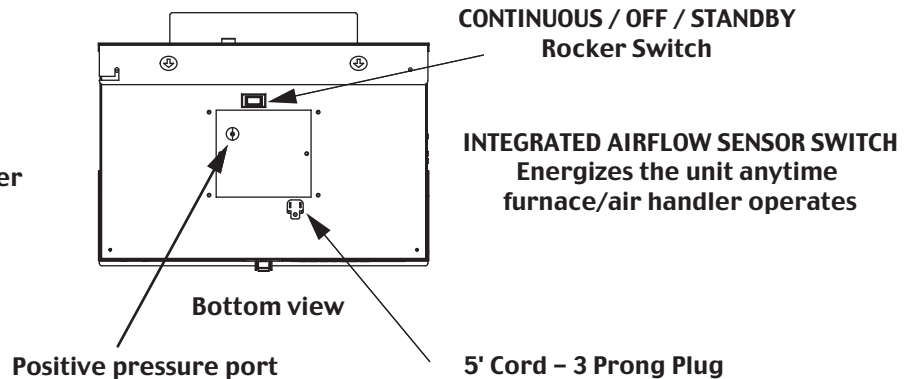
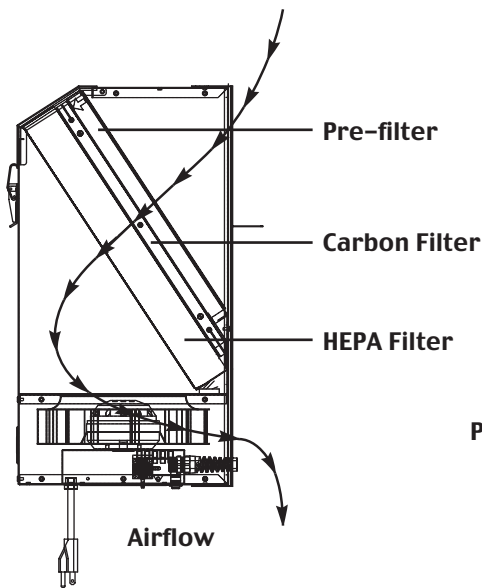
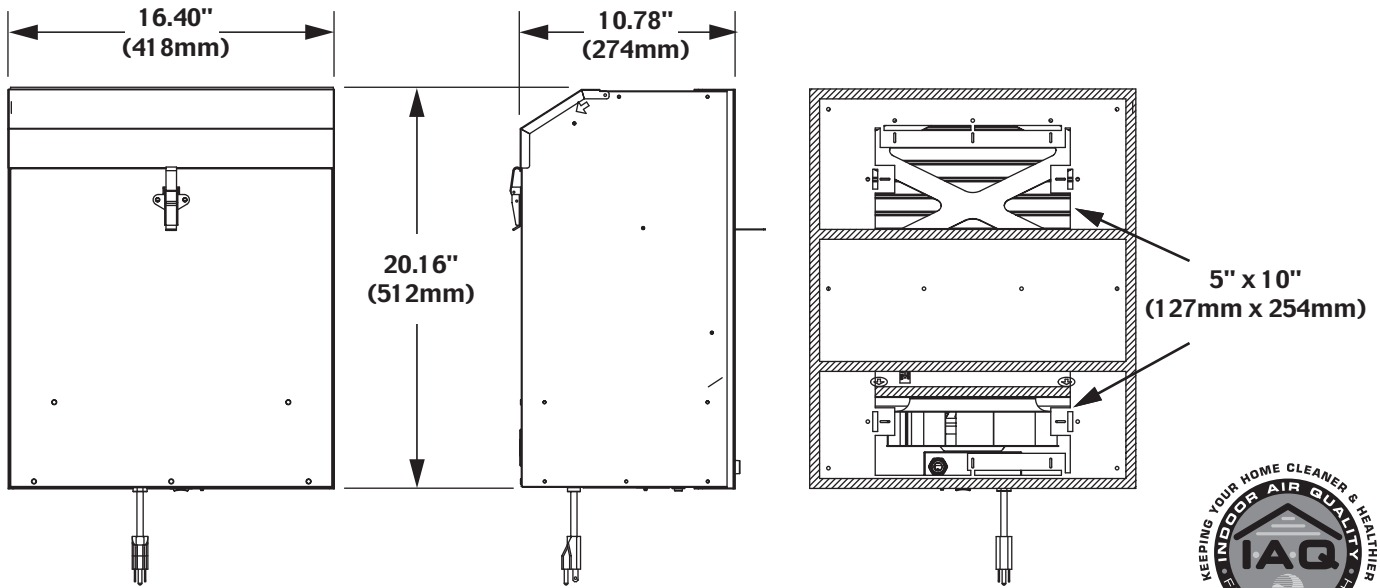

Specifications and Ratings

- Model: DM3000P
- Total assembled weight: 25 lbs
- Cabinet: 22 ga. steel w/ powder coat finish
- Motor: ebm motor w/backward curved blades
- Integrated airflow sensor switch. Energizes the unit anytime furnace/air handler operates
- Mounting: Suspended by mounting plate
- Ducts: 5" x 10" (127mm x 254mm)
- Pressure tube included
- Electrical requirements:

Volts	Frequency	Amps	Watts
120V	60Hz	1.0A	150W

 5' plug-in power cord w/ 3-prong plug

Contacts

Submitted by:	Date:
Qty:	Model #:
Comments:	
Project #:	
Location:	
Architect:	
Engineer:	
Contractor:	



United States
 1712 Northgate Blvd.,
 Sarasota, FL. 34234
 Phone: 800.747.1762; 941.309.6000
 Fax: 800.487.9915; 941.309.6099
 www.fantech.net
 info@fantech.net

Canada
 50 Kanalfakt Way,
 Bouctouche, NB E4S 3M5
 Phone: 800.565.3548; 506.743.9500
 Fax: 800.747.8116; 506.743.9600
 www.fantech.ca
 info@fantech.ca

Article #: 600707
 Rev Date: 080404